

USERS MANUAL FOR EUROMEX MICROTOME MT.5503

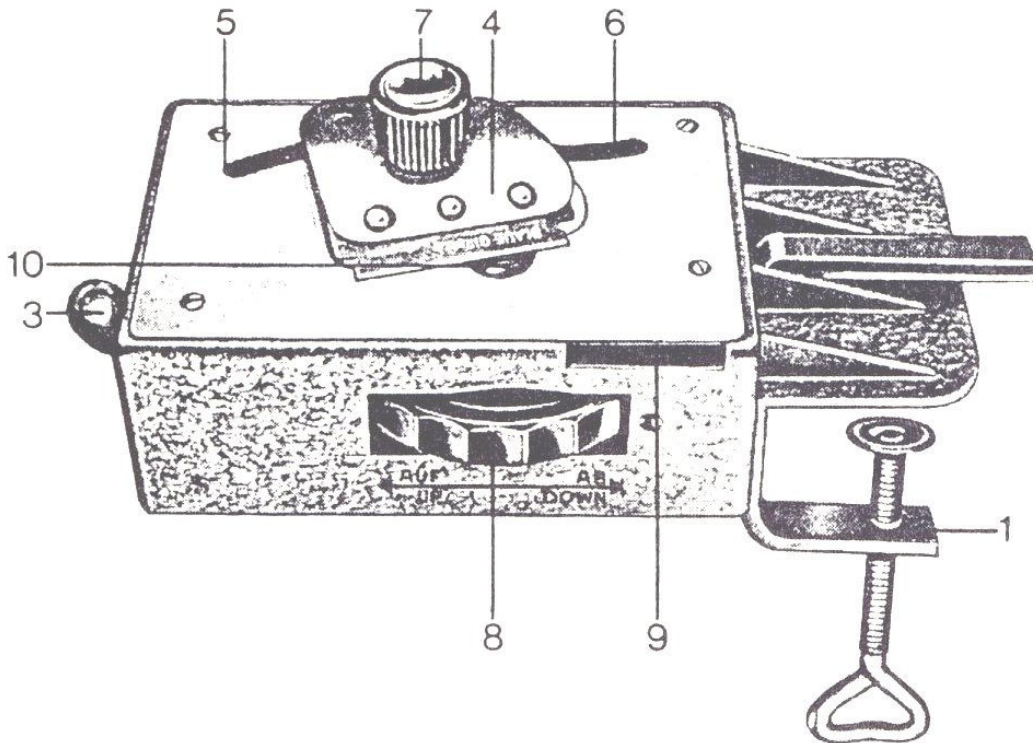

Fastening the microtome: With the aid of the provided clamp the microtome is clamped to a table, or other flat stable surface.

Placing the specimen: Place the feed-device into its starting position by turning knob (8) in the direction of the arrow to DOWN until it is stopped. Place the blade holder (4) into its starting position (5). Push lever (3) to the right as far as it will go and then hold it firmly in that position. Then place the specimen (10), either from the top or from the bottom, into the opening of the feed device. By releasing lever (3) the specimen will be firmly secured.

The specimen should be at least 40 mm. of length, and not thicker as 12 mm. in diameter.

Sectioning the specimen: The specimen (10) should protrude slightly above the cutting plate. For the start the protruding part of the specimen is clipped off. The sectioning is achieved by gently pulling the blade holder (4) towards the specimen (10) until it reaches its final position (6). When doing this the guiding knob (7) should be gently depressed. After completing each sectioning operation return the blade to its starting position (5).

To raise the specimen: Turn knob (8) in the direction of the arrow UP. The cutting of thin sections can begin once the cutting face of the specimen is straight and when the blade throws off sections of even thickness.

Cutting thin sections: Turn knob (8) about two or three clicks before each section. Each turn will raise the specimen about 25/1000mm. Sections of less than 25 microns can be obtained. Keep spreading water onto the cutting plate, the blade and the sectioning with the camel hair brush. Now insert a microscope slide into slot (9). With the aid of the brush gently transfer the sections onto the slide. Purposely the specimen is raised less and less with each sectioning so as to obtain in succession sections of decreasing thinness.

The quality of the sections and their thinness can be constantly checked under the microscope. The thinness of the sections depends greatly upon the type of material used for sectioning. Even hard, woody specimens can be cut successfully, but a new razorblade should be used more frequently. When knob (8) has reached its topmost position and will not raise the specimen any higher it has to be turned all the way back to its original position and the specimen will have to be re-positioned. To change the blade release knob (7).

After use dry the microtome to remove all moisture, other than that no care is required.

Always return the feed device to the topmost position by turning knob (8) before placing the microtome into its wooden cabinet.

TIPS

Numerous plants are suitable for immediate clipping, as for example the stalk of the primula, auralia, hydrangea, elm leaves, beech leaves and dandelion leaves.

Hard specimen can be suitably prepared by boiling them in water in which some glycerine has been added.

Specimen which are too soft can be hardened by leaving them in highly concentrated alcohol (or spirit) for a few days. Very soft specimen can be hardened by placing them in the deep-freeze compartment of a refrigerator.

For colouring of plant specimen EUROMEX has many staining-fluids available.

EUROMEX Microscopen B.V.
HOLLAND

www.euromex.com

USERS MANUAL FOR EUROMEX MICROTOME MT.5503

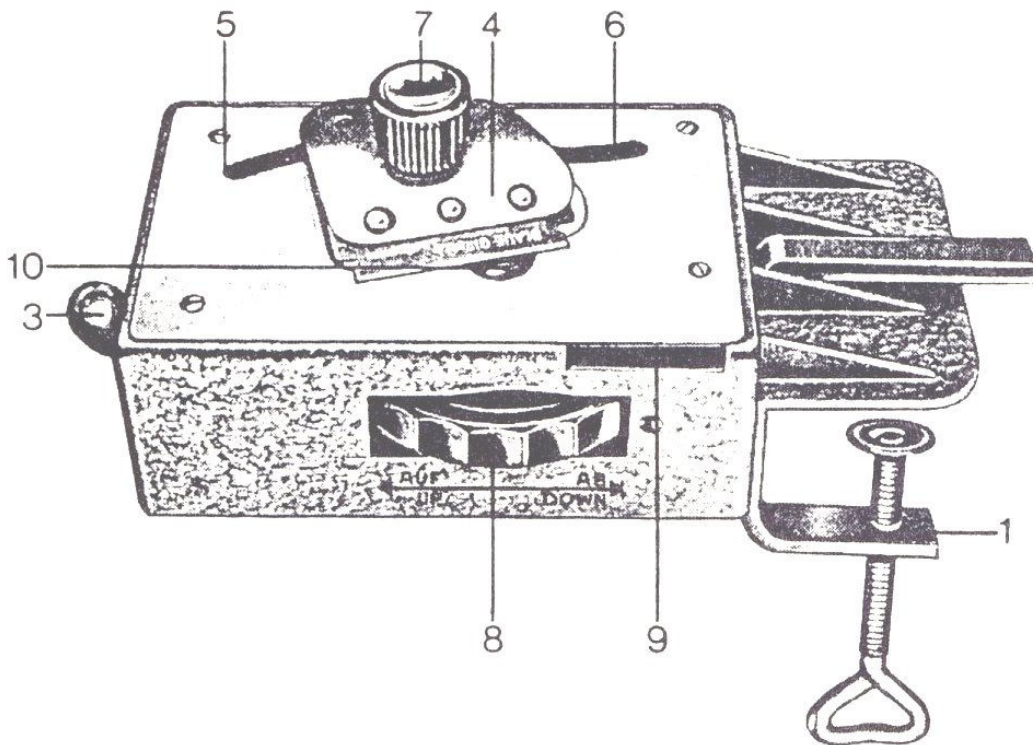

Fastening the microtome: With the aid of the provided clamp the microtome is clamped to a table, or other flat stable surface.

Placing the specimen: Place the feed-device into its starting position by turning knob (8) in the direction of the arrow to DOWN until it is stopped. Place the blade holder (4) into its starting position (5). Push lever (3) to the right as far as it will go and then hold it firmly in that position. Then place the specimen (10), either from the top or from the bottom, into the opening of the feed device. By releasing lever (3) the specimen will be firmly secured.

The specimen should be at least 40 mm. of length, and not thicker as 12 mm. in diameter.

Sectioning the specimen: The specimen (10) should protrude slightly above the cutting plate. For the start the protruding part of the specimen is clipped off. The sectioning is achieved by gently pulling the blade holder (4) towards the specimen (10) until it reaches its final position (6). When doing this the guiding knob (7) should be gently depressed. After completing each sectioning operation return the blade to its starting position (5).

To raise the specimen: Turn knob (8) in the direction of the arrow UP. The cutting of thin sections can begin once the cutting face of the specimen is straight and when the blade throws off sections of even thickness.

Cutting thin sections: Turn knob (8) about two or three clicks before each section. Each turn will raise the specimen about 25/1000mm. Sections of less than 25 microns can be obtained. Keep spreading water onto the cutting plate, the blade and the sectioning with the camel hair brush. Now insert a microscope slide into slot (9). With the aid of the brush gently transfer the sections onto the slide. Purposely the specimen is raised less and less with each sectioning so as to obtain in succession sections of decreasing thinness.

The quality of the sections and their thinness can be constantly checked under the microscope. The thinness of the sections depends greatly upon the type of material used for sectioning. Even hard, woody specimens can be cut successfully, but a new razorblade should be used more frequently. When knob (8) has reached its topmost position and will not raise the specimen any higher it has to be turned all the way back to its original position and the specimen will have to be re-positioned. To change the blade release knob (7).

After use dry the microtome to remove all moisture, other than that no care is required.

Always return the feed device to the topmost position by turning knob (8) before placing the microtome into its wooden cabinet.

TIPS

Numerous plants are suitable for immediate clipping, as for example the stalk of the primula, auralia, hydrangea, elm leaves, beech leaves and dandelion leaves.

Hard specimen can be suitably prepared by boiling them in water in which some glycerine has been added.

Specimen which are too soft can be hardened by leaving them in highly concentrated alcohol (or spirit) for a few days. Very soft specimen can be hardened by placing them in the deep-freeze compartment of a refrigerator.

For colouring of plant specimen EUROMEX has many staining-fluids available.

EUROMEX Microscopen B.V.
HOLLAND

www.euromex.com